

Certified according to DIN EN ISO 9001

## Technical Datasheet



# HM...F

**Turbine Flow Meters**  
with Flange Connections

## Application

Turbine flow meters serve to accurate measurement of continuous and discontinuous flow rate values. This turbine flow meter is most suited for liquids with low and middle viscosity, such as for example water, emulsions, mixtures containing glycol and light oils. The large range of different pipe connections and structural sizes allows using these flow meters in various applications and in various industrial sectors

## Principle and Design

The turbine flow meters KEM are indirect volume counters built on the principle of using the counter with the Woltmann turbine impeller. The energy coming from the flow of the liquid sets in motion a centrally and rotatably mounted rotor. The number of the rotor revolutions is directly proportional to the volumetric liquid flow. The speed of rotation of the turbine rotor is contactlessly sensed through the wall of the flowmeter body. The impulses generated by each turbine blade correspond to a certain accurate volumetric flow of the measured medium.

The number of pulses for a certain period of time corresponds to the value of the medium flow rate expressed, for example, in litres per minute. The lightweight turbine wheel allows quick response to changes in the value of the medium flow rate (< 50 m/s).

### Applications

- Tap and demineralised water
- Fuels
- Liquefied gases
- Pharmaceutical liquids
- Fuel oil
- Solvents

### Features

- Short response time (> 50 ms)
- Dynamic measuring system
- Temperature: -196°C to +350°C
- Several nominal sizes
- Pressure up to PN 400 / 6.000 PSI
- DIN- and ASME flanges available as standard (further flanges on request)
- Robust carbide bearings

## Technical Data

Metric flanges as per DIN-EN 1092-1 Form B												
Type	Measuring range	K-Factor <sup>1)</sup>	Frequency <sup>1)</sup>	DN <sup>2)</sup>	L <sup>2)</sup>	D <sup>2)</sup>						
						l/min	pulses/l	Hz	PN 16	PN 40	PN 100	PN 160
003	0.3 to 1.5	32,000 (32,500)	1,000 (1,000)	15	110	95	95	105	105	130	130	145
004	0.5 to 4	24,000 (19,000)	1,700 (1,250)									
005	0.8 to 6	17,800 (17,800)	1,740 (1,780)									
006	1.2 to 10	11,000 (11,000)	1,750 (1,750)									
007	2.0 to 20	5,200 (5,200)	1,800 (1,800)									
009	3.3 to 33	1,900 (4,200)	1,080 (1,800)									
011	6.0 to 60	1,300 (2,700)	1,080 (2,600)									
009	3.3 to 33	1,900 (4,200)	1,080 (1,800)	25	150	115	115	140	140	150	160	180
011	6.0 to 60	1,300 (2,700)	1,080 (2,600)									
013	8.5 to 85	900 (1,900)	1,350 (2,700)									
017	12 to 120	380 (840)	1,300 (2,600)									
019	15 to 150	310 (650)	800 (1,650)									
022	20 to 200	217 (450)	800 (1,600)									
024	25 to 250	170 (360)	800 (2,000)									
011	6.0 to 60	1,300 (2,700)	1,080 (2,600)	40	174	150	150	170	170	185	195	220
017	12 to 120	380 (840)	1,300 (2,600)									
019	15 to 150	310 (650)	800 (1,650)									
022	20 to 200	217 (450)	800 (1,600)									
024	25 to 250	170 (360)	800 (2,000)									
028	30 to 360	155 (320)	960 (2,000)									
030	35 to 400	130 (270)	860 (1,850)									
036	40 to 500	60 (135)	600 (1,200)									
040	50 to 750	105 (110)	1,320 (1,400)									
017	12 to 120	380 (840)	1,300 (2,600)	50	210	165	165	195	195	200	210	235
019	15 to 150	310 (650)	800 (1,650)									
022	20 to 200	217 (450)	800 (1,600)									
024	25 to 250	170 (360)	800 (2,000)									
028	30 to 360	155 (320)	960 (2,000)									
030	35 to 400	130 (270)	860 (1,850)									
036	40 to 500	60 (135)	600 (1,200)									
040	50 to 750	105 (110)	1,320 (1,400)									
050	70 to 1,200	65	1,400									
036	40 to 500	60 (135)	600 (1,200)	65	258	185	185	220	220	230	255	290
040	50 to 750	105 (110)	1,320 (1,400)									
050	70 to 1,200	65	1,400									
065	100 to 2,000	25	850									
040	50 to 750	105 (110)	1,320 (1,400)	80	316	200	200	230	230	255	275	305
050	70 to 1,200	65	1,400									
065	100 to 2,000	25	850									
080	160 to 3,200	11	615									
065	100 to 2,000	25	850	100	386	220	235	265	265	300	335	370
080	160 to 3,200	11	615									
100	250 to 5,000	7	560									
		pulses/m <sup>3</sup>	Hz									
125	300 to 6,600	4,500	600 (1,200)	125	400	250	270	315	higher pressures on request			
150	350 to 10,000	3,400	600 (1,200)	150	400	285	300	355				
200	430 to 13,400	415	600 (1,200)	200	400	340	375	430				
250	830 to 25,000	266	600 (1,200)	250	500	405	450	505				

1) The data on K-factors and maximum frequencies are average values at 1mm<sup>2</sup>s. The numbers of pulses and frequencies at higher viscosities may vary. Exact values can be found in individual calibration records.

2) See drawing (page 6)

\* Detailed type code on request

# HM...F Turbine Flow Meters

Inch flanges as per AMSE B 16.5 (class 150 - 2500)											
Type	Measuring range	K-Factor <sup>1)</sup>	Frequency <sup>1)</sup>	DN <sup>2)</sup>	L <sup>2)</sup>	D <sup>2)</sup>					
						150	300	600	900	1500	2500
	l/min	pulses/l	Hz								
003	0.3 to 1.5	32,000 (32,500)	1,000 (1,000)	½"	110	88.9	95.2	95.2	120.6	120.6	133.3
004	0.5 to 4	24,000 (19,000)	1,700 (1,250)								
005	0.8 to 6	17,800 (17,800)	1,740 (1,780)								
006	1.2 to 10	11,000 (11,000)	1,750 (1,750)								
007	2.0 to 20	5,200 (5,200)	1,800 (1,800)								
009	3.3 to 33	1,900 (4,200)	1,080 (1,800)								
011	6.0 to 60	1,300 (2,700)	1,080 (2,600)								
009	3.3 to 33	1,900 (4,200)	1,080 (1,800)	1"	150	107.9	123.8	123.8	149.2	149.2	158.7
011	6.0 to 60	1,300 (2,700)	1,080 (2,600)								
013	8.5 to 85	900 (1,900)	1,350 (2,700)								
017	12 to 120	380 (840)	1,300 (2,600)								
019	15 to 150	310 (650)	800 (1,650)								
022	20 to 200	217 (450)	800 (1,600)								
024	25 to 250	170 (360)	800 (2,000)								
011	6.0 to 60	1,300 (2,700)	1,080 (2,600)	1½"	174	127	155.6	155.6	177.8	177.8	203.2
017	12 to 120	380 (840)	1,300 (2,600)								
019	15 to 150	310 (650)	800 (1,650)								
022	20 to 200	217 (450)	800 (1,600)								
024	25 to 250	170 (360)	800 (2,000)								
028	30 to 360	155 (320)	960 (2,000)								
030	35 to 400	130 (270)	860 (1,850)								
036	40 to 500	60 (135)	600 (1,200)								
040	50 to 750	105 (110)	1320 (1,400)								
017	12 to 120	380 (840)	1,300 (2,600)	2"	210	152.4	165.1	165.1	215.9	215.9	234.9
019	15 to 150	310 (650)	800 (1,650)								
022	20 to 200	217 (450)	800 (1,600)								
024	25 to 250	170 (360)	800 (2,000)								
028	30 to 360	155 (320)	960 (2,000)								
030	35 to 400	130 (270)	860 (1,850)								
036	40 to 500	60 (135)	600 (1,200)								
040	50 to 750	105 (110)	1,320 (1,400)								
050	70 to 1,200	65	1,400								
036	40 to 500	60 (135)	600 (1,200)	2½"	258	177.8	190.5	190.5	244.5	244.5	266.7
040	50 to 750	105 (110)	1,320 (1,400)								
050	70 to 1,200	65	1,400								
065	100 to 2,000	25	850								
040	50 to 750	105 (110)	1,320 (1,400)	3"	316	190.5	209.5	209.5	241.3	266.7	304.8
050	70 to 1,200	65	1,400								
065	100 to 2,000	25	850								
080	160 to 3,200	11	615								
065	100 to 2,000	25	850	4"	386	228.6	254	273	292.1	311.2	355.6
080	160 to 3,200	11	615								
100	250 to 5,000	7	560								
		pulses/m <sup>3</sup>	Hz								
125	300 to 6,600	4,500	600 (1,200)	5"	400	254	279.4	330.2	higher pressures on request		
150	350 to 10,000	3,400	600 (1,200)	6"	400	279.4	317.5	355.6			
200	430 to 13,400	415	600 (1,200)	8"	400	342.6	381	419.1			
250	830 to 25,000	266	600 (1,200)	10"	500	406.4	444.5	508			

1) The data on K-factors and maximum frequencies are average values at 1mm<sup>2</sup>s. The numbers of pulses and frequencies at higher viscosities may vary. Exact values can be found in individual calibration records.

2) See drawing (page 6)

General	
Linearity	± 1% of actual flow (≤ 1 mm <sup>2</sup> /s; up to 0.1% with linearization electronic)
Repeatability	± 0.1%
Measuring range	Standard: 1:10 Extended : on request
Viscosity range	0,8 to 100 mm <sup>2</sup> /s
Materials	Housing: as per DIN 1.4571 (SS316Ti) Wheels: as per DIN 1.4122 / 1.4460 (SS329) Bearing: Carbide
Medium temperature	-196°C to +350°C (higher temperatures on request)
Dimensions	See drawing (page 6)

## Pickup Selection

Criteria \ Type		VTE *	WT */ WI*	VIE *	IF * / VIEG	VTC *	VTB *	TD *	VHE *	FOP *
Drilling type <sup>1)</sup>		E	E	E	E	E	E	D	E	E/F
Medium temperature	≤ +70°C									
	≤ +120°C					X	X		X	X
	≤ +150°C	X	X	X						
	≤ +350°C				X					
EX-Approval		X	X	X	X	X	X			X
Frequency output		X	X	X	X	X			X	X
Dual frequency output										
Analogue output 4 - 20 mA			X			X				
Forward / backward recognition										
Display Vorort						X	X			
Linearization			X			X				
Supply 12 - 24 V		X	X	X	X	X			X	
Supply battery							X			X
Interface			X			X				

1) Thread types: E: single pickup / D: dual pickup / F: FOP-pickup

\* Ordering code (please see separate datasheet)

## Dimensional Drawings (mm) - HM...F

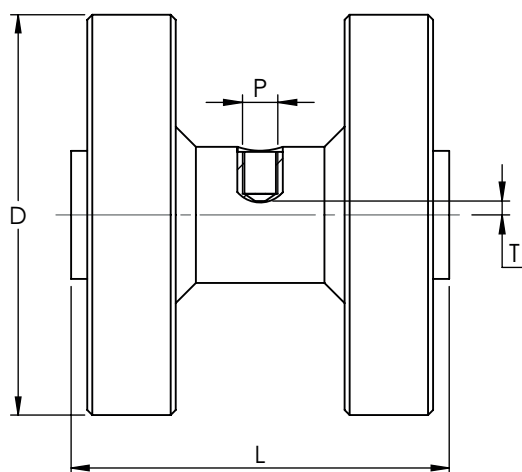

**Metric flanges as per DIN-EN 1092-1 Form B**

Type HM	D							DN	L	P <sup>1)</sup>	T <sup>2)</sup>
	PN 16	PN 40	PN 100	PN 160	PN 250	PN 320	PN 400				
HMF 003 - 011	95	95	105	105	130	130	145	15	110	E	-
HMF 009 - 024	115	115	140	140	150	160	180	25	150	E	-
HMF 011 - 040	150	150	170	170	185	195	220	40	174	E	-
HMF 017 - 050	165	165	195	195	200	210	235	50	210	E	-
HMF 036 - 065	185	185	220	220	230	255	290	65	258	E	-
HMF 040 - 080	200	200	230	230	255	275	305	80	316	E	-
HMF 065 - 100	220	235	265	265	300	335	370	100	386	E	-
HMF 125	250	270	315	higher pressures on request				125	400	E	-
HMF 150	285	300	355					150	400	E	-
HMF 200	340	375	430					200	400	E	-
HMF 250	405	450	505					250	400	E	-

1) See "Pickup Selection" table (Page 5)

2) Note: Total height is calculated by adding hole depth (T) and the height of the pickup (separate data sheet).

Inch flanges as per AMSE B 16.5 (class 150 - 2500)										
Type HM	D						DN	L	P <sup>1)</sup>	T <sup>2)</sup>
	150	300	600	900	1500	2500				
HMF 003 - 011	88.9	95.2	95.2	120.6	120.6	133.3	½"	110	E	-
HMF 009 - 024	107	123.8	123.8	149.2	149.2	158.7	1"	150	E	-
HMF 011 - 040	127	155.6	155.6	177.8	177.8	203.2	1 ½"	174	E	-
HMF 017 - 050	152.4	165.1	165.1	215.9	215.9	234.9	2"	210	E	-
HMF 036 - 065	177.8	190.5	190.5	244.5	244.5	266.7	2 ½"	258	E	-
HMF 040 - 080	190.5	209.5	209.5	241.3	266.7	304.8	3"	316	E	-
HMF 065 - 100	228.6	254	273	292.1	311.2	355.6	4"	386	E	-
HMF 125	254	279.4	330.2	higher pressures on request			5"	400	E	-
HMF 150	279.4	317.5	355.6				6"	400	E	-
HMF 200	342.6	381	419.1				8"	400	E	-
HMF 250	406.4	444.5	508				10"	400	E	-

1) See "Pickup Selection" table (Page 5)

2) Note: Total height is calculated by adding hole depth (T) and the height of the pickup (separate data sheet).

## KEM Headquarter

Liebigstraße 5  
85757 Karlsfeld  
Germany

T. +49 8131 59391-0  
F. +49 8131 92604

[info@kem-kueppers.com](mailto:info@kem-kueppers.com)

## KEM Service & Repairs

Wetzeller Straße 22  
93444 Bad Kötzing  
Germany

T. +49 9941 9423-0  
F. +49 9941 9423-23

[info@kem-kueppers.com](mailto:info@kem-kueppers.com)

*More distributors & partners can be found at:  
[www.kem-kueppers.com](http://www.kem-kueppers.com)*

Your local partner:



[www.kem-kueppers.com](http://www.kem-kueppers.com)  
[info@kem-kueppers.com](mailto:info@kem-kueppers.com)