

In-Line Immersible Thermal Gas Mass Flow Meter with Flow Conditioning

Features

- **Direct mass flow monitoring eliminates need for separate temperature and pressure inputs**
- **Built-in flow conditioner which eliminates velocity-profile distortions caused by upstream disturbances**
- **Accuracy +/- 1% of reading plus 0.5% of full scale**
- **Patented Dry-Sense™ technology eliminates sensor drift**
- **State-of-the-art calibration facility insures a highly accurate calibration that matches the application**
- **Field validation of meter electronics and sensor resistance verifies flow meter performance**
- **One-second response to changes in flow rate**
- **FM, CSA, PED and ATEX certified for hazardous areas**
- **CE approved**
- **Multipoint options available**
- **Integrated purge option available**
- **Optional HART, Modbus and Profibus DP available, Foundation Fieldbus (pending)**



SIERRA
EXPERIENCE OUR PASSION FOR FLOW!

SIERRA INSTRUMENTS, NORTH AMERICA • 5 Harris Court, Building L • Monterey, California • (800) 866-0200 • +1 (831) 373-0200 • Fax: +1 (831) 373-4402

SIERRA INSTRUMENTS, EUROPE • Bijlmansweid 2 • 1934 RE Egmond a/d Hoef • The Netherlands • +31 (0) 72 5071400 • Fax +31 (0) 72 5071401

SIERRA INSTRUMENTS, ASIA • Second Floor Building 5 • Senpu Industrial Park • 25 Hangdu Road Hangtoun Town • Pu Dong New District • Shanghai, P.R. China 201316 • +8621 5879 8521/22 • Fax: +8621 5879 858

Flat-Trak™ Model 780S

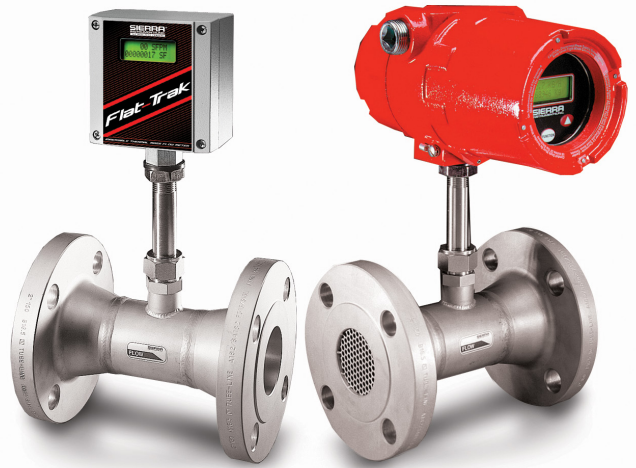

Description

The Flat-Trak™ Model 780S flow body eliminates velocity profile distortions, swirl and temperature stratifications in the gas stream and reduces the amount of upstream piping required for accurate flow measurement.

The versatile microprocessor-based transmitter integrates the functions of flow measurement, flow-range adjustment, meter validation and diagnostics, in either a probe-mounted or remote housing. Mass flow rate and totalized flow, as well as other configuration variables, are displayed on the meter's optional 2 x 12 LCD display. The programmable transmitter is easily configured via an RS-232 communication port and Sierra's Smart Interface™ software, or via the display and magnetic switches on the instrument panel.

Sierra's state-of-the-art calibration facility insures that the calibration will match the application, and our patented Dry-Sense™ thermal sensor insures the Model 640S will hold this calibration over time.

Sierra's Smart Interface™ software guides you through a procedure to fully validate instrument performance. The meter is available with a variety of input power, output signals, mounting and packaging options.

Dimensional Specifications

1/4-inch NPT—Front View (E2)

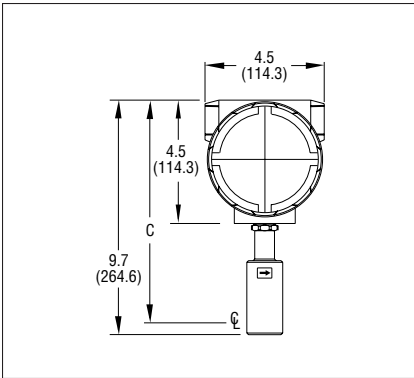

1/4-inch NPT—Side View (E2)

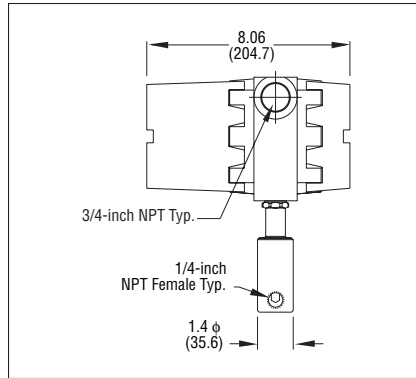

Sizes for NPT

SIZES FOR NPT			
Size	C	L1	L2
1/4-inch	8.40 (198.1)	— (213.4)	—
1/2-inch	6.90 (175.3)	2.20 (55.9)	6.50 (165.1)
3/4-inch	6.90 (175.3)	2.20 (55.9)	7.00 (177.8)
1-inch	9.10 (228.6)	1.50 (38.1)	3.50 (88.9)
1.5-inch	9.40 (238.8)	2.25 (57.2)	5.25 (133.4)
2-inch	10.20 (259.1)	3.50 (88.9)	7.50 (190.5)
3-inch	11.20 (284.5)	4.00 (101.6)	10.00 (254)
4-inch	11.20 (290.8)	4.00 (101.6)	12.00 (304.8)
6-inch	12.20 (309.9)	6.00 (152.4)	18.00 (457.2)
8-inch	13.20	8.00	24.00

1/2-inch and 3/4-inch NPT—Front View (E2)

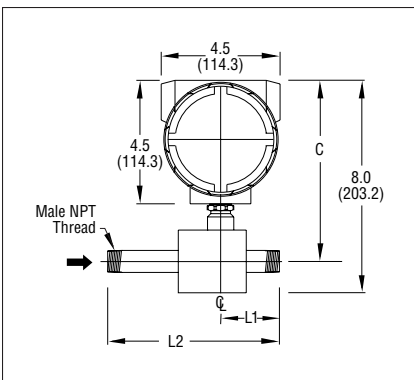

1/2-inch and 3/4-inch NPT—Side View (E2)

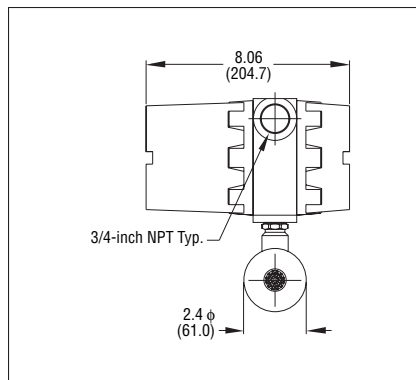

1-inch Through 8-Inch NPT—Front View (E2)

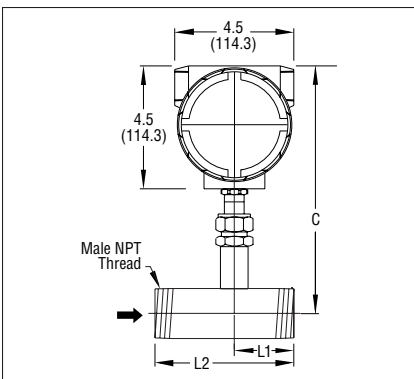

1-inch Through 8-Inch NPT—Side View (E2)

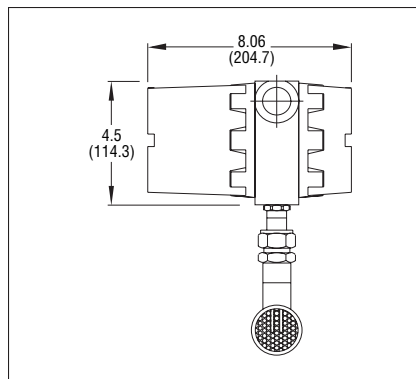

1-inch to 8-Inch NPT—Front/Side View (EN2)

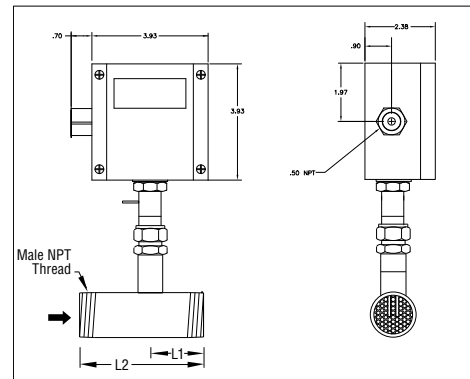

1/2 and 3/4-inch 150 lb Flange—Front View (E2)

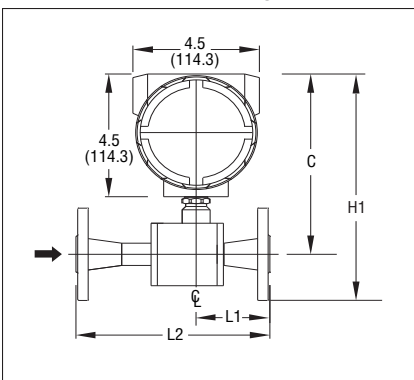

1/2 and 3/4-inch 150 lb Flange—Side View (E2)

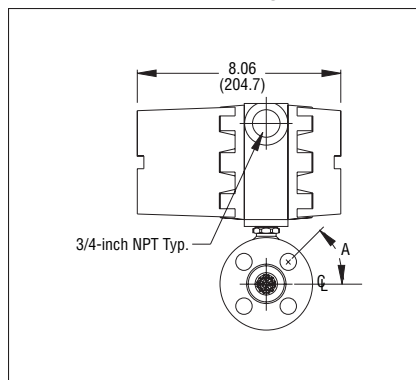

Sizes for 150 lb ANSI Flange

SIZES FOR 150 LB ANSI FLANGES					
Size	H1	C	L1	L2	A
1/2-inch	7.79 (197.9)	6.94 (176.3)	2.60 (66.0)	6.95 (176.5)	45°
3/4-inch	7.79 (197.9)	6.94 (176.3)	2.78 (70.6)	7.56 (192.0)	45°

Dimensional Specifications

1" Through 8" 150 lb Flange—Front View (E2)

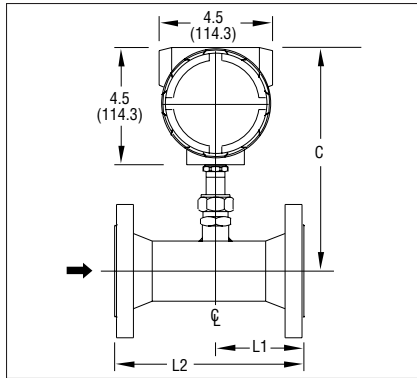

1" Through 8" 150 lb Flange—Side View (E2)

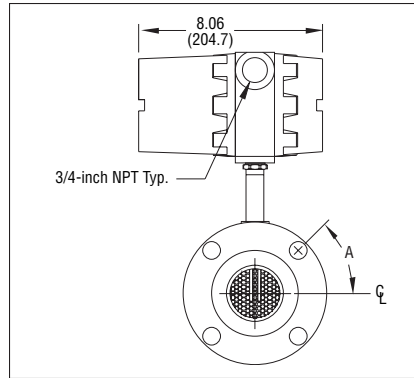

DN Flange—Front View (E2)

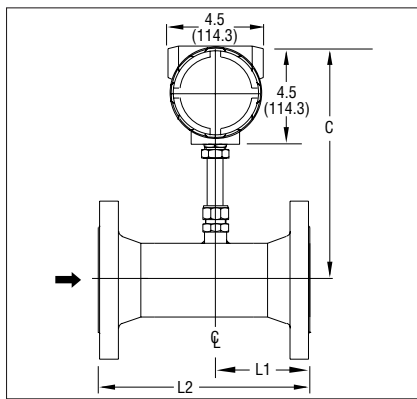

DN Flange—Side View (E2)

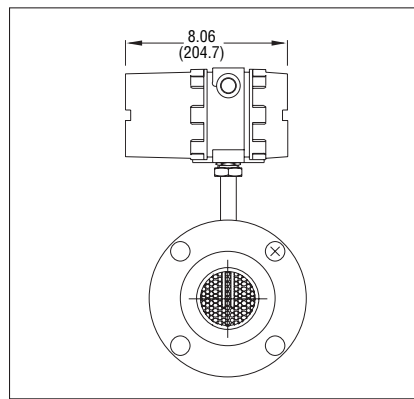

NEMA 4X Enclosure - Front View (EN2)

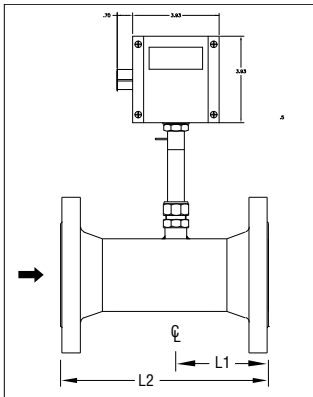

NEMA 4X Enclosure—Side View (EN2)

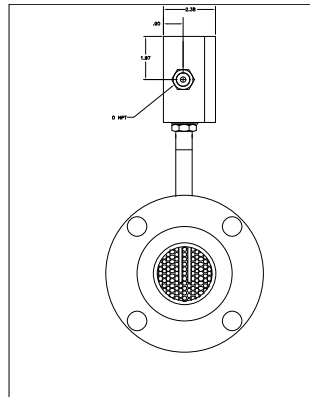

Remote Mounted with Junction Box (E4)

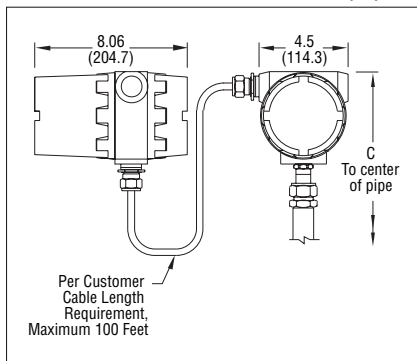

Remote Mounted with Junction Box (EN4)

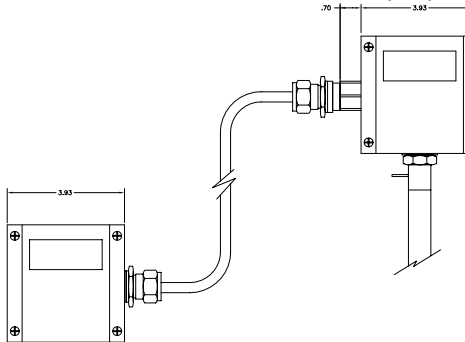

SIZES FOR 150 LB ANSI FLANGES

Size	C	L1	L2	A
1-inch	9.10 (238.8)	3.60 (91.4)	7.40 (188.0)	45°
1.5-inch	9.40 (238.8)	3.80 (96.5)	7.50 (190.5)	45°
2-inch	10.20 (259.1)	3.50 (88.9)	7.50 (190.5)	45°
3-inch	11.20 (284.5)	4.00 (101.6)	10.00 (254.0)	45°
4-inch	11.20 (284.5)	4.00 (101.6)	12.00 (304.8)	22.5°
6-inch	12.20 (309.9)	6.00 (152.4)	18.00 (457.2)	22.5°
8-inch	13.20 (335.3)	8.00 (203.2)	24.00 (609.6)	22.5°

SIZES FOR PN16 DN FLANGES

Size	C	L1	L2
DN25	8.88 (225.6)	3.18 (80.8)	7.40 (188.0)
DN40	9.50 (241.3)	3.61 (91.7)	7.40 (188.0)
DN50	10.70 (271.8)	3.34 (84.8)	7.10 (180.3)
DN80	10.50 (266.7)	4.14 (105.2)	10.20 (259.1)
DN100	10.60 (269.2)	4.57 (116.1)	12.60 (320.0)
DN150	12.40 (315.0)	6.77 (172.0)	18.90 (480.1)
DN200	14.50 (368.3)	8.47 (215.1)	24.40 (619.8)

SIZES FOR REMOTE MOUNTED

Size	C
1/4 - inch	8.4 (198.1)
1/2-inch	6.9 (175.3)
3/4-inch	6.9 (175.3)
1-inch	9.10 (231.1)
1.5-inch	9.40 (238.8)
2-inch	10.20 (259.1)
3-inch	11.20 (284.5)
4-inch	11.20 (284.5)
6-inch	12.20 (309.9)
8-inch	13.20 (335.3)

Performance Specifications

Accuracy

+/- 1% of reading + 0.5 % of full scale

Repeatability

+/- 0.2% of full scale

Temperature Coefficient

+/- 0.02% of reading per °F within +/- 50° F of customer specified conditions

+/- 0.03% of reading per °F within +/- 50° F to 100° F of customer specified conditions

+/- 0.04% of reading per °C within +/- 25° C of customer specified conditions

+/- 0.06% of reading per °C within +/- 25° C to 50° C of customer specified conditions

Pressure Coefficient

.02% per psi for air, consult factory for other gases

Response Time

One second to 63% of final velocity value

Operating Specifications

Gases

Most gases compatible with 316 L stainless steel

Gas Pressure (2 limitations)

Mechanical design pressure:

Compression fittings: 500 psig (34.5 barg)

150 lb flange or PN16 DN (-40° F to 100° F): 230 psig (15.9 barg)

150 lb flange or PN16 DN (250° F): 185 psig (12.8 barg)

150 lb flange or PN16 DN (450° F): 155 psig (10.7 barg)

NPT (-40° F to 250° F): 500 psig (34.5 barg)

Pressure Drop

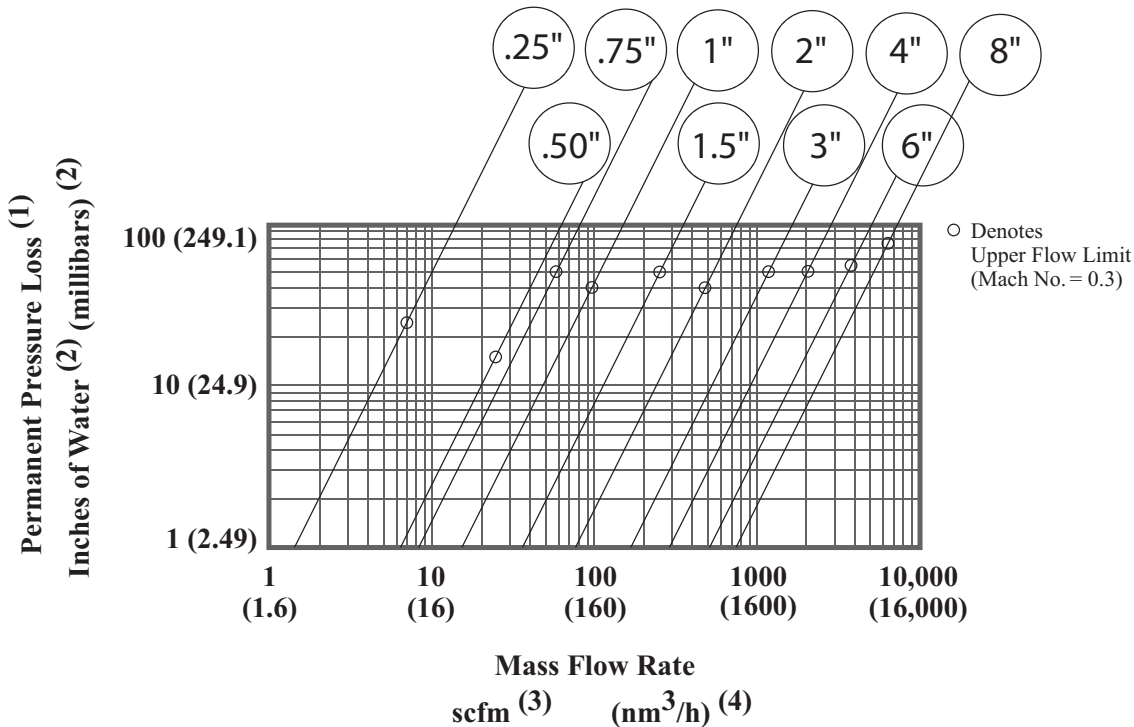

Notes:

(1) For air and nitrogen at 20 °C temperature and 1 atmosphere pressure.

(2) 1 inch of water at 60 °F = 0.0361 psi.

1 millibar = 0.001 bar = 100 pascal = 0.0145 psi.

(3) At base conditions of 21.1 °C temperature and 1 atmosphere pressure.

(4) At base conditions of 0 °C temperature and 1 atmosphere pressure.

(5) Built-in flow conditioner consists of two separate perforated plates in series.

Operating Specifications (cont.)

Gas & Ambient Temperature

Gas -40° F to 350° F (-40° C to 177° C)
 Ambient -40° F to 120° F (-40° C to 50° C)

Leak Integrity

5 X 10⁻⁹ cc/sec of helium maximum

Power Requirements

18 to 30 VDC (regulated), 625 mA maximum
 100 to 240 VAC, 50/60 Hz, 15 watts maximum

Output Signal

Linear 0–5 VDC or 0-10 VDC, 1000 ohms minimum load resistance or
 Linear 4–20 mA proportional to mass flow rate,
 700 ohms maximum resistance power supply dependent
 User-selectable: Active non-galvanically separated or Passive
 galvanically separated (loop power required)
 See Digital Communications options below

Alarms

Hard contact user-adjustable high and low
 Dead band adjustable with Smart Interface™ software
 Relay ratings Maximum 400 VDC or VAC (peak), 140 mA

Displays

Alphanumeric 2 x 12 digit backlit LCD
 Adjustable variables via on-board switches (password protected)
 or with Smart Interface™ software
 Adjustable variables. . . Full scale (50 to 100 %)
 Time Response (1 to 7 seconds)
 Correction factor setting (0.5 to 5)
 Zero and span
 High and low alarm settings

Totalizer

Seven digits (9,999,999) in engineering units
 Resettable by software, on-board switches or external magnet

Software

Smart Interface™ Windows®-based software
 Minimum 8 MB of RAM, preferred 16 MB of RAM
 RS-232 communication
 Additional features. . . Alarm dead band adjustment
 Zero cut-off adjustment
 Linearization adjustment
 Save / Load configurations
 Fully guided flow meter validation

Digital Communications Options

Pulse (not available with E2-NR)
 Modbus RTU (not available with P3 option)
 Profibus DP (available E2/E4-P2 configuration only)
 HART universal commands (available E2/E4-P2 configuration only)
 Foundation Fieldbus (available E2/E4-P2 configuration only) pending

Physical Specifications

Wetted Materials

316L stainless steel
 Carbon steel flow bodies available in some sizes

Enclosure

Hazardous-Area Location Enclosure (IP66) and NEMA 4X (IP65) are
 powder-coated cast aluminum

Electrical Connections

Two 3/4 inch NPT . . . Hazardous-Area Location Enclosure (IP66)
 One 1/2 inch NPT . . . NEMA 4X Enclosure (IP65)

Piping Requirements

STRAIGHT PIPE LENGTH REQUIREMENTS AT 1 ATM			
Piping Condition	780S Flat-Trak™		Orifice Plate ⁽³⁾
	Upstream ⁽¹⁾	Downstream ⁽²⁾	
Single 90° Elbow or T-Piece	1D	0D	28D
Reduction (4:1)	3D	0D	14D
Expansion (4:1)	3D	0D	30D
After Control Valve	3D	0D	32D
Two 90° Elbows (In Same Plane)	3D	0D	36D
Two 90° Elbows (Different Planes)	5D	0D	62D

- Notes: (1) Number of diameters (D) of straight pipe required between upstream disturbance and the flow meter.
 (2) Number of diameters (D) of straight pipe required downstream of the flow meter.
 (3) For comparison purposes only. Table shows number of diameters (D) of upstream straight pipe length required for an ISO Standard 5167 Orifice Plate with a Beta Ratio of 0.7.
 (4) Consult factory for pressure effects.

Certifications

CE (All enclosures)
 CSA (Explosion proof for Class I, Division 1, Groups B, C, D)
 ATEX (II 2 GD Ex d IIC T6 ... T2; IP 66 T70 °C ... T280 °C)
 FM (Explosion proof for Class I, Division 1, Groups B, C, D; dust-ignition
 proof for Class II, III, Division 1, Groups E, F, G)
 IP65, NEMA 4X T6 -40° C to 70° C ambient
 PED optional

Ordering the Model 780S

780S

List
Options

PARENT MODEL NUMBER
780S Flat-Trak™ Immersible Thermal In-Line Meter

AGENCY APPROVALS
NAA Non-Agency Approved Meter
CSA Explosion Proof for Class I, Division 1, Groups B, C, D
ATEX II 2 GD Ex d IIC T6 ... T2; IP 66 T70 °C ... T280 °C
FM Explosion Proof for Class I, Division 1, Groups B, C, D

FLOW BODY—STAINLESS STEEL

NPT	ANSI Flange	DN Flange		Size
	150 lb	PN16	PN40	
N1	N/A			1/4-inch
N2	F2			1/2-inch
N3	F3			3/4-inch
N4	F4	D4	GD4	1-inch (DN25)
N5	F5	D5	GD5	1.5-inch (DN40)
N6	F6	D6	GD6	2-inch (DN50)
N7	F7	D7	GD7	3-inch (DN80)
N8	F8	D8	GD8	4-inch (DN100)
N9	F9	D9	GD9	6-inch (DN150)
N10	F10	D10	GD10	8-inch (DN200)

ENCLOSURES
E2 Hazardous-Area Location Enclosure
E3(ft) Remote Hazardous-Area Location Enclosure (Only with ATEX Meters)
E4(ft) Remote Hazardous-Area Location Enclosure with Junction Box
EN2 NEMA 4X (IP65)
EN4(ft) Remote NEMA 4X (IP65) with Junction Box
 Specify Cable Length in Parentheses, Maximum 200 feet (60 m),
 Length in Feet using 5 ft. increments to 20 ft., 10 ft. increments to 200 ft.

INPUT POWER
P2 18 to 30 VDC
P3 100 to 240 VAC (Not Available on EN enclosures)

OUTPUT SIGNAL
V1 0–5 VDC, Linear
V3 0–10 VDC, Linear
V4 4–20 mA, Linear

DISPLAY
NR No Readout
DD Digital Display

GAS CODE
0 Air
1 Argon
2 CO₂
3 Chlorine (Correlation)
4 Digester
5 Digester (Correlation)
6 Helium
7 Hydrogen
8 CH₄
9 CH₄ (Correlation)
10 Nitrogen
11 Oxygen (Correlation)
12 Propane
13 Propane (Correlation)
99 Other

OPTION 1 (DIGITAL COMMUNICATIONS)
PULSE Pulse (not avail. w/ E2-NR)
MB Modbus (not avail. w/ P3)
DP Profibus DP (available E2/E4-P2 config only)
HART Universal Commands (available E2/E4-P2 config only)
FF Foundation Fieldbus (available E2/E4-P2 config only) Pending

OPTION 2 (CERTIFICATES)
PT Pressure Test Certificate
CC Certificate of Conformance
NC NACE Certificate
MC Materials Certificate
LT Leak Test Certificate